

April 22, 2020

NATIONAL AJET MASK SEW-A-THON

Donate handmade masks to care facilities and hospitals across Japan to support their efforts against the Coronavirus (COVID-19).

Join your prefecture's volunteer efforts in this initiative to donate masks to local facilities.

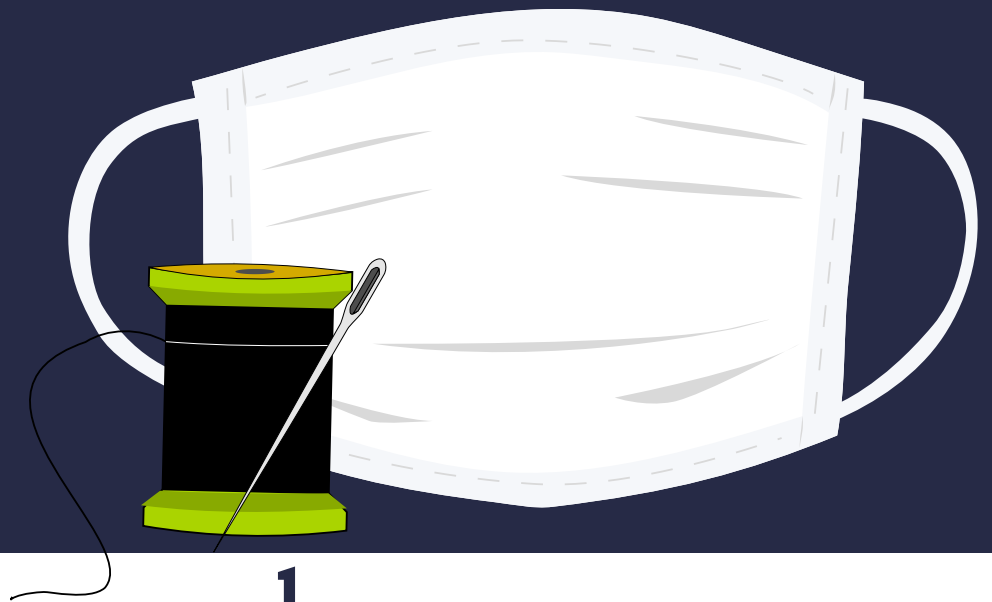

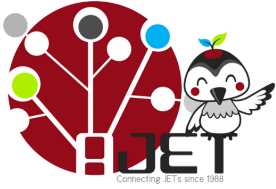

2020 MASK SEW-A-THON



Prompted by the many ALTs and CIRs concerned with offering their help during this global pandemic, and the many current global initiatives such as the #millionmaskchallenge, AJET will be conducting a Mask Sew-A-Thon initiative with the hopes that volunteers all across Japan can virtually come together to support the many care givers, hospitals workers and essential personel who are risking their lives every day to help and save others.

Many hospitals in Japan do not have enough masks or fear running out within less than a month.

(PR TIMES, "新型コロナウイルス感染症拡大...")

The Association for Japan Exchange and Teaching (AJET) is a national volunteer organization of JET Program Participants. It serves the JET community by building support networks, organizing useful information, and offering resources to enhance the lives of the Program participants in Japan and abroad. It maintains various resources such as a counseling service and online magazine, and voices the opinions and concerns of JETs to the Council of Local Authorities for International Relations (CLAIR) and other Japanese government ministries that manage the JET Program.

Along with the above activities, AJET values volunteering and charity, and works to promote volunteering in Japan not only by mainting a volunteer database, but also by partnering with various non-profit organizations in the country.

PARTICIPATION GUIDELINES



The Sew-A-Thon will begin on April 22, 2020 and end either on May 25, 2020 or when there is no longer a national need.

AJET is hoping that every JET Program community in all 47 prefectures will come together and join the initiative to provide handmade masks to care facilities in every prefecture. This project is open for participation by not only current JET Program participants and alumni, but also Japanese and foreign nationals within every prefectures' communities.

▼ HOW TO PARTICIPATE

For prefectural AJET associations that would like to participate:

Each prefecture's local AJET committee or association is to contact local care facilities (hospitals, orphanages, etc.) that may be in need and are accepting handmade mask donations. Once those numbers are gathered by each prefectural association, they will be pledged to AJET for the Mask Sew-A-Thon. Volunteers in each respective prefecture will work together to make the handmade masks and reach the pledged number for donation.

Prefectural AJET committees or associations should get in contact with the AJET Director of Volunteering at natasha.taliferro@ajet.net for further details on how to pledge donations for your prefecture and on how to get in contact with local care facilities.

For individuals who would like to participate:

1. Join the AJET 2020 Mask Sew-A-Thon group and event page on Facebook.
2. Get in touch with your prefecture's local AJET committee or association for information about the need in your area.
3. Follow the material and sanitation guidelines on pages 4 and 5, and start sewing!
4. Send your clean and completed masks to your prefecture's AJET committee or association's donation leader.
5. Spread the word about the this initiative and project!

PARTICIPATION GUIDELINES



As it is difficult to provide the safest type of masks (those with adequate filtration materials) to healthcare officials who deal directly with infected patients (due to lack of or hard-to-find proper filtration materials), these handmade masks are ideally for other care workers, patients, etc. in hospitals and care facilities who do not require proper mask protection such as the N95 mask.

*While fabric masks will not offer the full protection of a surgical or N95 mask, regular fabric masks (masks without filtration pockets) have been shown to capture at least 50% of *Bacillus atrophaeus* bacteria and Bacteriophage MS2 particles (bacteria and particles that are 5 times smaller than the Coronavirus).*

▼ Mask Guidelines

For this Mask Sew-A-Thon project, AJET would like volunteers to make pleated or non-pleated double-sided masks. Cloth materials for the masks should be 100% Cotton or cotton-polyester blend woven fabrics. The masks must have at least two layers of fabric of different colors or patterns to indicate to the user which side has touched their face. Additionally, fabrics must be washed before sewing for sanitary purposes and to pre-shrink the fabric.

IMPORTANT NOTE: The handmade masks made for this project must be washed by the wearer every day or after every day of use.

Necessary Materials for Handmade Masks

1. Two Patterns of Cotton or Cotton-Polyester Blend Woven Fabric
2. Elastic Cord (for 2 straps around the ears)
3. Thin Wiring, Optional (for a snug fit across the nose)
4. Thread (of any color)
5. Sewing Supplies (sewing needle or machine, sewing pins, a ruler and scissors)

Instructions on how to make these masks and mask patterns or templates can be found on the United State CDC website or on YouTube at:

(Hand-sewn)

<https://www.youtube.com/watch?v=31CBnLw6wDU>

<https://www.youtube.com/watch?v=RjlzW8uaxYs>

(Machine-Sewn)

https://www.youtube.com/watch?v=S9RWII2-5_4

<https://www.youtube.com/watch?v=o8OyV15ua24>

(Optional, With a Filter Pocket)

https://www.youtube.com/watch?v=zm_NmpdgWWA



PARTICIPATION GUIDELINES

Below are handmade mask instructions created by the United States Center for Disease Control (CDC). Although the instructions are to be used with a sewing machine, these masks can also be made by hand-sewing.

Sewn Cloth Face Covering

Materials

- Two 10"x6" rectangles of cotton fabric
- Two 6" pieces of elastic (or rubber bands, string, cloth strips, or hair ties)
- Needle and thread (or bobby pin)
- Scissors
- Sewing machine

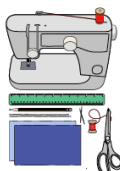

Tutorial

1. Cut out two 10-by-6-inch rectangles of cotton fabric. Use tightly woven cotton, such as quilting fabric or cotton sheets. T-shirt fabric will work in a pinch. Stack the two rectangles; you will sew the cloth face covering as if it was a single piece of fabric.

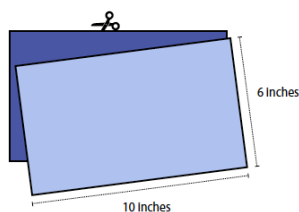

2. Fold over the long sides 1/4 inch and hem. Then fold the double layer of fabric over 1/2 inch along the short sides and stitch down.

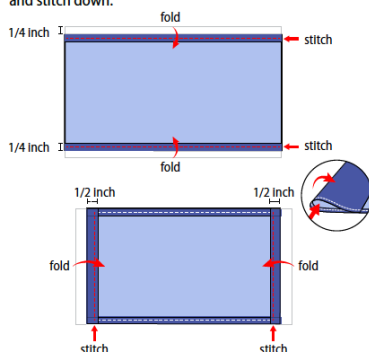

3. Run a 6-inch length of 1/8-inch wide elastic through the wider hem on each side of the cloth face covering. These will be the ear loops. Use a large needle or a bobby pin to thread it through. Tie the ends tight. Don't have elastic? Use hair ties or elastic head bands. If you only have string, you can make the ties longer and tie the cloth face covering behind your head.

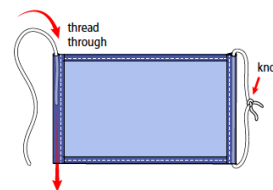

4. Gently pull on the elastic so that the knots are tucked inside the hem. Gather the sides of the cloth face covering on the elastic and adjust so the mask fits your face. Then securely stitch the elastic in place to keep it from slipping.

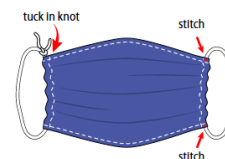

Sanitation Guidelines

Before making any handmade masks, please be sure to wash and sanitize your hands, the materials necessary for sewing, and your work station.

You should avoid making masks if you are sick or think you might be getting sick.

Mask materials should also be kept away from household pets and other animals.

Sources

- "What Are The Best Materials for Making DIY Masks?," Smartairfilters.com
- "Testing the Efficacy of Homemade Masks: Would They Protect in an Influenza Pandemic?," Disaster Medicine and Public Health Preparedness Journal and Cambridge University
- "Use of Cloth Face Coverings to Help Slow the Spread of COVID -19," Center for Disease Control

If you have any questions or inquires, please contact Natasha Taliferro, the AJET Director of Volunteering, at natasha.taliferro@ajet.net.

